

# Analysis of the CO<sub>2</sub> and NH<sub>3</sub> Reaction in an Aqueous Solution by 2D IR COS: Formation of Bicarbonate and Carbamate

HoSeok Park,<sup>†</sup> Young Mee Jung,<sup>‡</sup> Jong Kyun You,<sup>†</sup> Won Hi Hong,<sup>\*,†</sup> and Jong-Nam Kim<sup>\*,§</sup>

Department of Chemical and Biomolecular Engineering (BK21 Program), KAIST, 373-1 Guseong-dong, Yusong-gu, Daejeon, Republic of Korea, Department of Chemistry, Kangwon National University, Chunchon 200-701, Republic of Korea, and Chemical Research Center, KIER, 71-2 Jang-dong, Yusong-gu, Daejeon, Republic of Korea

Received: February 2, 2008; Revised Manuscript Received: May 12, 2008

The two-dimensional (2D) infrared correlation spectra obtained from the reaction time- and concentration-dependent IR spectra elucidates the reaction of CO<sub>2</sub> and NH<sub>3</sub> in an aqueous solution for CO<sub>2</sub> absorption. In the synchronous 2D correlation spectra, the interrelation of the proton with carbamate and bicarbonate indicates that the pH level affected the formation reactions of the two products. Furthermore, the interrelation of carbamate with bicarbonate confirmed the conversion of carbamate into bicarbonate with the release of protons (or the decrease of the pH). From the experimental results including the asynchronous 2D correlation spectra, the reaction of the CO<sub>2</sub> and aqueous ammonia proceeded through the following steps: formation of carbamate, formation of bicarbonate, release of protons, and conversion of carbamate into bicarbonate. The analysis of the formation of carbamate and bicarbonate by 2D infrared correlation spectroscopy provides useful information on the reaction mechanism of CO<sub>2</sub> and NH<sub>3</sub> in aqueous solutions.

## Introduction

Carbon dioxide emissions need to be reduced because they are a major greenhouse gas that causes global warming. Absorption of carbon dioxide by various chemical solvents is considered to be the most effective technology to capture CO<sub>2</sub>. To date, alkanolamine solutions have been commonly used as absorbents to remove CO<sub>2</sub> from flue gas. Recently, aqueous ammonia solutions have been recognized as an alternative chemical solvent for CO<sub>2</sub><sup>1–4</sup> because of their advantages over amine absorbents in terms of lower costs, higher CO<sub>2</sub> absorption capacities, lower decomposition temperatures of ammonium bicarbonate, and less corrosive environments for the absorber material.<sup>5</sup>

Despite the relatively small amount of research conducted on aqueous ammonia as a CO<sub>2</sub> absorbent, there has been a long-standing interest in the absorption reaction between CO<sub>2</sub> and NH<sub>3</sub>, especially in connection with industrially relevant processes, such as the Solvay process, and academically important chemistry, such as carbamation. The reaction between CO<sub>2</sub> and NH<sub>3</sub> in aqueous media can occur at room temperature (298.25 K) with 1 atm as follows:

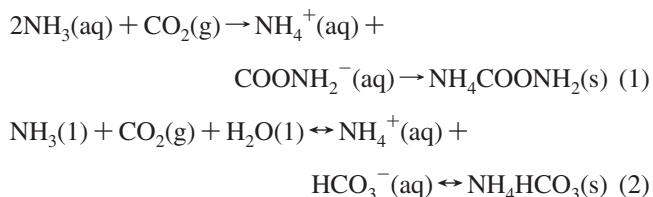

\* Corresponding author. Tel: +82-042-869-3919. E-mail: whhong@kaist.ac.kr.

<sup>†</sup> KAIST.

<sup>‡</sup> Kangwon National University.

<sup>§</sup> KIER.

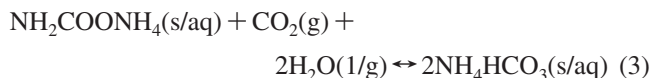

The formation of ammonium (NH<sub>4</sub><sup>+</sup>) and carbamate (NH<sub>2</sub>COO<sup>-</sup>) ions via reaction 1 is very fast and irreversible at low temperatures.<sup>6</sup> However, reactions 2 and 3 are reversible, resulting in the formation of ammonium bicarbonates.<sup>7</sup> Ammonium carbamates can be converted into ammonium bicarbonates via reaction 3. The formation of carbonate as a minor product is negligible because of its slow formation reaction and fast conversion reaction into bicarbonate under the experimental conditions used in this study (298 K, 1 atm). In particular, the formation of carbamate and bicarbonate is of prime importance in terms of the effect of the two components on the CO<sub>2</sub> working capacity and regeneration energy.<sup>8,9</sup> A fundamental understanding of the reaction of CO<sub>2</sub> and NH<sub>3</sub> in aqueous solutions, however, has thus far proved elusive, primarily because of the complexity of these systems and the difficulties in monitoring the kinetic reaction changes.<sup>10</sup> Herein, the reaction of CO<sub>2</sub> and NH<sub>3</sub> in an aqueous solution is verified by using a two-dimensional infrared correlation spectroscopy (2D IR COS).

2D IR COS is defined by two independent wavenumbers,<sup>11–13</sup> generated by a cross-correlation analysis of the dynamic fluctuations of IR signals induced by an external perturbation, such as temperature, time, stress, concentration, and so on. Some of the notable features of the generalized 2D correlation spectra include the simplification of complex spectra consisting of many overlapped peaks, the enhancement of the spectral resolution by spreading the peaks along the second dimension, the establishment of unambiguous assignments through the correlation of selectively coupled bands by using various interaction mechanisms, and the determination of the sequence of spectral peak emergence.<sup>11–13</sup> Therefore, 2D COS is particularly suitable to elucidate complex chemical reactions such as CO<sub>2</sub> absorption. In a synchronous 2D correlation spectrum, the auto peaks located at the diagonal positions represent the overall susceptibility of

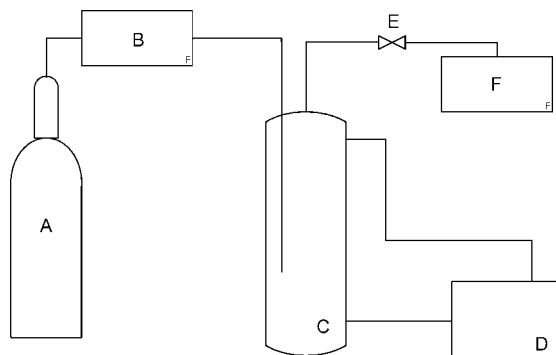
**SCHEME 1: Diagram of Reactor System for CO<sub>2</sub> Scrubbing**

A : CO<sub>2</sub> cylinder, B : Mass flow controller, C : CO<sub>2</sub> Scrubber,  
D : Constant temperature Water Circulator, E : Sampling Port, F : FT-IR

the corresponding spectral region to change in the spectral intensity as an external perturbation is applied to the system, whereas the cross peaks located at the off-diagonal positions of a synchronous 2D correlation spectrum reveal simultaneous or coincidental changes of spectral intensities that are observed at two different spectral variables ( $\nu_1$  and  $\nu_2$ ).<sup>11–13</sup> In contrast, an asynchronous 2D correlation spectrum consisting of cross peaks only provides information that is useful to interpret the kinetics of the chemical/physical reactions: the relative temporal relationship and the order of the actual sequence of individual reaction processes.<sup>11–13</sup> The intensity of an asynchronous 2D correlation spectrum represents sequential, or successive, changes of spectral intensities measured at  $\nu_1$  and  $\nu_2$ . An asynchronous cross peak develops only if the intensities of two spectral features change out of phase (i.e., delayed or accelerated) with each other. If the signs of synchronous and asynchronous cross peaks are the same, the intensity change at  $\nu_1$  occurs before  $\nu_2$ . If the signs of synchronous and asynchronous cross peaks are different, the intensity change at  $\nu_1$  occurs after  $\nu_2$ .

In this work, the chemical reactions of CO<sub>2</sub> and NH<sub>3</sub> in an aqueous solution were analyzed by focusing on the formation of carbamate and bicarbonate as major components by using a 2D IR COS obtained from the reaction time- and concentration-dependent FT-IR spectra.

**Experimental Section**

The schematic diagram of the experimental system that investigates the reaction between CO<sub>2</sub> and NH<sub>3</sub> is shown in Scheme 1. The temperature of the solution was kept within  $\pm 0.5$  K of the set point during the experiments by circulating water through the water jacket around the reactor. The bubble blowing apparatus, the inlet port of which was attached to a glass filter for CO<sub>2</sub> bubbling and mixing, was a glass bottle with a 45 mm inner diameter containing 200 mL of ammonia solution. The CO<sub>2</sub> gas was obtained from a CO<sub>2</sub> gas cylinder (>99.9%). The CO<sub>2</sub> flow rate of 970 mL/min was controlled by using mass flow controllers (MFC, MKS). All experiments in this study were performed at room temperature conditions (298 K). The ammonia solution was obtained from Junsei (28 wt%) and was diluted by using deionized water. The concentrations of NH<sub>3</sub> in this experiment were 5, 10, 15, 20, and 25 wt%. The dry powders of ammonium carbamates and ammonium bicarbonates were used as the standards for product identification, were supplied by Sigma-Aldrich (99%), and were not purified further.

FT-IR spectra were collected by a JASCO FT-IR 470 plus as attenuated total reflection mode. The pressure was equal in

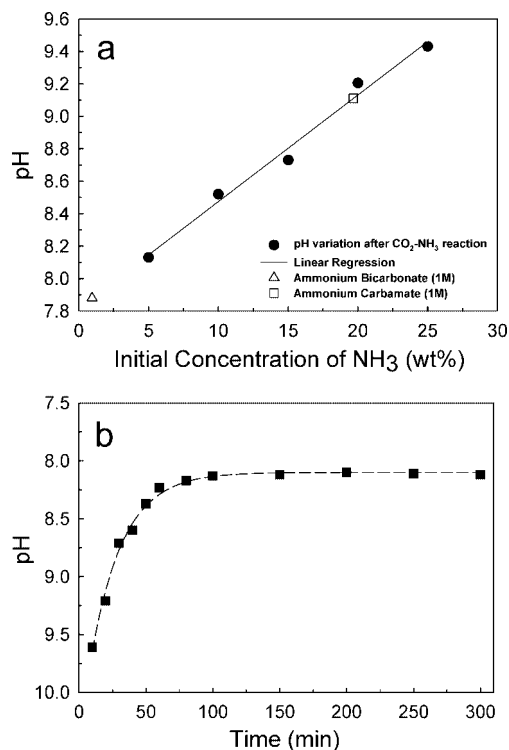

**Figure 1.** pH variation of the solutions (a) as a function of the initial concentration of ammonia in the range of 5–25 wt% and (b) after the CO<sub>2</sub> and NH<sub>3</sub> reaction in an aqueous solution at 5 wt% as a function of the reaction time.

all samples to avoid differences caused by the pressure and penetrating depth. Each spectrum, which was recorded as the average of 13 scans with a resolution of 1 cm<sup>-1</sup>, was taken from 4000 cm<sup>-1</sup> to 650 cm<sup>-1</sup>. Other regions, except 1900–900 cm<sup>-1</sup>, were omitted because of the independence of the peaks from the reaction. We collected each sample of 2 mL at the specific condition through a sampling port and then directly measured it to block the reaction of CO<sub>2</sub> and NH<sub>3</sub> further.

The synchronous and asynchronous 2D correlation spectra were obtained by using the same software as that described previously.<sup>14</sup> In light of recent publications concerning the normalization procedure in 2D correlation analyses,<sup>14</sup> we tested various methods and found that the best results were obtained by using non-normalized data.

**Results and Discussion**

The pH of reaction media, which is influenced by the formation of products as well as the consumption of reactants, is important in controlling the reaction route of CO<sub>2</sub>-NH<sub>3</sub> in an aqueous solution.<sup>9</sup> As the reaction of NH<sub>3</sub> with CO<sub>2</sub> as acidic gas in an aqueous solution proceeds, the pH of the solution decreases, and the CO<sub>2</sub> loading increases.<sup>8,9</sup> The pHs of the solutions linearly increased in the range of 5–25 wt% with the initial concentration of ammonia, as shown in Figure 1a. The pHs of standard ammonium carbamate and bicarbonate were consistent with those reported in previous work.<sup>15</sup> Figure 1b shows the pH variation of the solution after the CO<sub>2</sub> and NH<sub>3</sub> reaction in an aqueous solution at 5 wt% as a function of the reaction time. The rapid drop of pH until the reaction time of 60 min was associated with the fast reaction of CO<sub>2</sub> and NH<sub>3</sub> at the initial reaction time. In contrast, the smooth decrease of pH above 60 min of reaction time was due to the conversion reaction from ammonium carbamates to ammonium bicarbonates.<sup>1</sup>

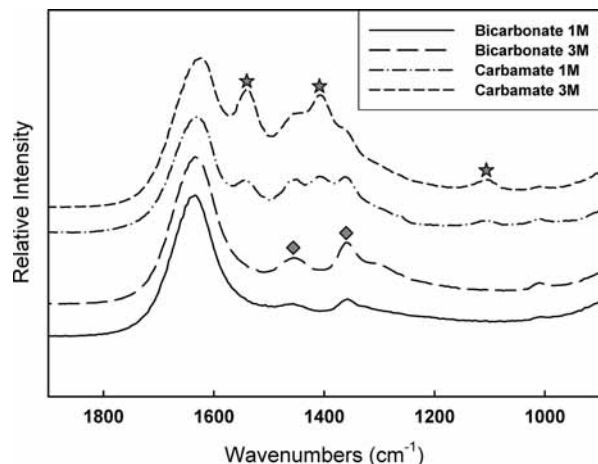

**Figure 2.** IR spectra of standard ammonium carbamate and ammonium bicarbonate at 1 and 3 M in aqueous solutions. Asterisks were assigned to peaks of carbamates, whereas diamonds were assigned to those of bicarbonates.

FT-IR was used to assign the typical bands of standard ammonium bicarbonates and carbamates at 1 and 3 M aqueous solution, shown in Figure 2. The proton band was  $1612\text{ cm}^{-1}$ ,<sup>16</sup> and the three carbamate bands appeared in the range of  $900\text{--}1900\text{ cm}^{-1}$ . In previous results, there were six bands ascribed to the carbamates ion. However, it is impossible to differentiate the three carbamate bands below  $900\text{ cm}^{-1}$  because of the superposition of the bands from other components. The bands at approximately  $1550$  and  $1100\text{ cm}^{-1}$  were ascribed to the C=O asymmetric and symmetric stretching bands of  $\text{NH}_2\text{CO}_2^-$  groups, respectively.<sup>17</sup> In addition, the peak near  $1400\text{ cm}^{-1}$  was attributed to the C–N stretching band.<sup>18</sup> The two shoulder peaks of the C–N stretching band at  $1450$  and  $1350\text{ cm}^{-1}$  were attributed to the C–O asymmetric and symmetric bands of bicarbonate, respectively.<sup>19,20</sup> However, the ammonium carbamate in the aqueous system also had a relatively weak intensity of bands because of its dissolution and instantaneous conversion reaction into bicarbonate in water. The intensities of the shoulder bands at  $1450$  and  $1350\text{ cm}^{-1}$  were proportional to the concentration of ammonium bicarbonate from 1 to 3 M, indicating that these bands were attributed to ammonium bicarbonate. For the ammonium carbamate, the intensities of the three bands also increased with the concentration of ammonium carbamate. The intensities of the three bands that are stronger than those of the other peaks in the reaction products indicate that the formation reaction of carbamates via reaction 1 proceeds dominantly, and the content of carbamate ions increases.

Figure 3 shows the FT-IR spectra of the solutions after the  $\text{CO}_2$  and  $\text{NH}_3$  reaction in an aqueous solution at 5 wt% as a function of the reaction time. After the reaction of  $\text{CO}_2$  and  $\text{NH}_3$  for 10 min, the pH of the solutions reached approximately 9.5, which approached that of the standard ammonium carbamates in the 1 M solution (Figure 1a). The pH of the solutions dropped gradually to 8.1, which is close to that of ammonium bicarbonates. Consequently, the typical bands of ammonium carbamates were gradually weakened and almost disappeared. When comparing the IR spectra for 20 min of reaction time with the other IR spectra for reactions longer than 20 min, the former displayed relatively apparent bands of carbamate. Their pHs were near the pH of standard ammonium carbamate (Figure 1). After the ammonium carbamates were produced via reaction 1 at pH 9.5–9.2 during a reaction time of 10–20 min, ammonium bicarbonates were produced gradually by the

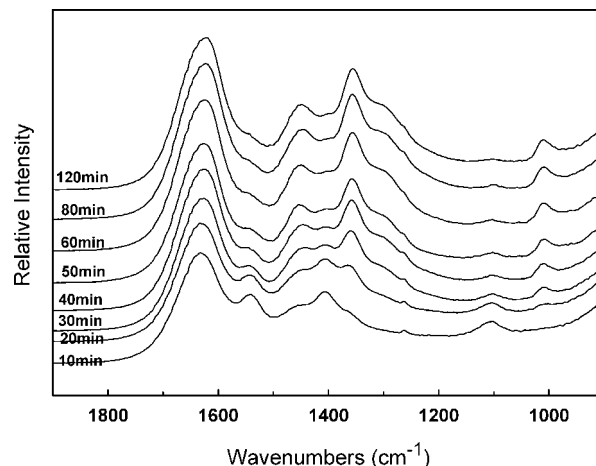

**Figure 3.** IR spectra of the solutions after the  $\text{CO}_2$  and  $\text{NH}_3$  reaction in an aqueous solution at 5 wt% as a function of the reaction time.

formation or conversion reactions via reactions 2 and 3. However, the IR spectra did not provide detailed information on the kinetic changes of reactions related to the formation of carbamate and bicarbonate.

In order to clarify the correlation among the reaction routes, such as the formation of carbamate and bicarbonate and the conversion of bicarbonate into carbamate, we applied the 2D COS to the reaction time-dependent FT-IR spectra in Figure 3. Figure 4 shows the synchronous and asynchronous 2D correlation spectra obtained from the reaction time-dependent IR spectra of the  $\text{CO}_2$  and aqueous ammonia at 5 wt%. As shown in the top section of Figure 4a, the power spectrum extracted along a diagonal line in the synchronous spectrum demonstrates that the band around  $1354\text{ cm}^{-1}$  contained an additional band at  $1304\text{ cm}^{-1}$  as a result of the conformational change of bicarbonate through different reaction routes and interactions with other components. Positive cross peaks at  $(1612, 1452)\text{ cm}^{-1}$  and  $(1612, 1354)\text{ cm}^{-1}$  in the synchronous 2D correlation spectrum indicate that the changes in the pH related to the proton peak were strongly interrelated with the two bicarbonate bands at  $1452$  and  $1354\text{ cm}^{-1}$ . When the absorption reaction of  $\text{CO}_2$  by  $\text{NH}_3$  in the aqueous solution occurred, the band intensity of the proton was enhanced (Figure 3). Furthermore, bicarbonate was formed via reaction 2 or 3 with a reduction of pH in the reaction solution, as confirmed by the existence of positive cross peaks and as shown in Figure 3. In contrast, the negative cross peak at  $(1354, 1536)\text{ cm}^{-1}$  elucidates that the change of spectra intensity of the band assigned to carbamate at  $1536\text{ cm}^{-1}$  was inversely proportional to that ascribed to bicarbonate at  $1354\text{ cm}^{-1}$ . The reciprocal relation of carbamate and bicarbonate bands confirmed the conversion reaction of carbamate into bicarbonate via reaction 3. As shown in the synchronous 2D correlation spectrum in Figure 5a, obtained from the concentration-dependent IR spectra (Supporting Information, Figure S1), the changes in the pH related to the proton band were also interrelated with bands of carbamate as a result of the positive cross peak at  $(1612, 1409)\text{ cm}^{-1}$ . As the pH of the solution decreased, the proton concentration increased, and protons reacted with the carbamate ions, causing them to become unstable.<sup>21</sup> In particular, the band of carbamate at  $1409\text{ cm}^{-1}$  was split into two bands at  $1411$  and  $1379\text{ cm}^{-1}$  because of its interactions with the proton, as shown in the asynchronous 2D correlation spectrum in Figure 5b. The unstable carbamate intermediate was

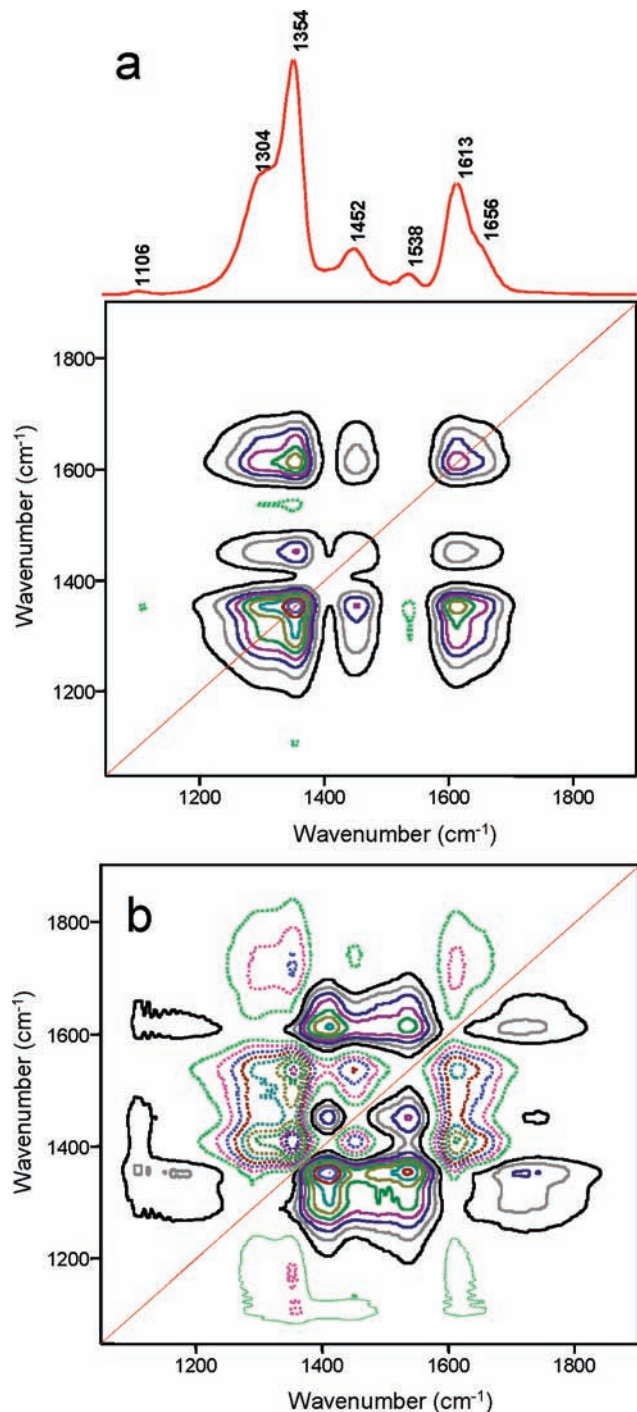

**Figure 4.** (a) Synchronous and (b) asynchronous 2D correlation spectra obtained from the reaction time-dependent IR spectra of the CO<sub>2</sub> and aqueous ammonia at 5 wt% in the range of 1900–900 cm<sup>-1</sup>. The solid and dotted lines represent positive and negative cross peaks, respectively.

converted into bicarbonate through conversion reaction 3, as supported by the reduction of carbamate bands after 20 min of reaction time (Figure 3). The formation reaction of carbamate via reaction 1 occurred at higher pH levels than that of the formation reaction of bicarbonate via reaction 2 (Figures 1 and 3). An analysis of the asynchronous 2D correlation spectrum in Figure 4 revealed the following sequence of changes in spectral intensities: 1409 (C–N stretching band of carbamate), 1452 (C–O asymmetric band of bicarbonate), 1354 (C–O symmetric band of bicarbonate), 1612 (proton band), 1107 (C=O symmetric stretching band

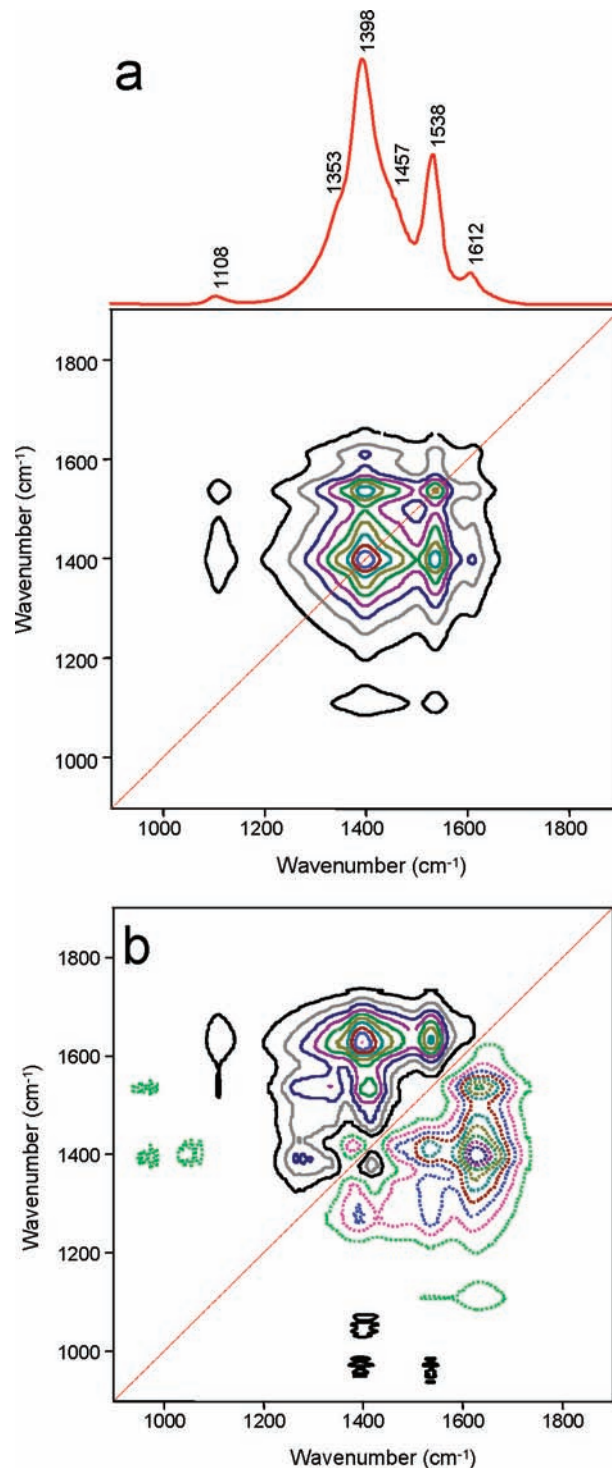

**Figure 5.** (a) Synchronous and (b) asynchronous 2D correlation spectra obtained from the concentration-dependent IR spectra of the CO<sub>2</sub> and aqueous ammonia at 5, 10, 15, 20, and 25 wt% in the range of 1900–900 cm<sup>-1</sup>. The solid and dotted lines represent positive and negative cross peaks, respectively.

of carbamate), and 1536 (C=O asymmetric stretching band of carbamate). Furthermore, the reaction route of CO<sub>2</sub> and NH<sub>3</sub> in an aqueous solution was confirmed by the results of 2D IR COS of CO<sub>2</sub> and aqueous ammonia at 15 wt% (Supporting Information, Figures S2 and S3). These findings clarify that the reaction of CO<sub>2</sub> and aqueous ammonia proceeded as follows: the formation of carbamate via reaction 1, the formation of bicarbonate via reaction 2, the release of

protons with the pH reduction, and the conversion of carbamate into bicarbonate via reaction 3.

### Conclusion

We demonstrated that the absorption reaction of CO<sub>2</sub> and aqueous ammonia occurred through the formation of carbamate and bicarbonate, and the conversion of carbamate into bicarbonate as confirmed by 2D IR COS obtained from the reaction time- and concentration-dependent IR spectra. Positive cross peaks at (1612, 1452), (1612, 1409), and (1612, 1354) cm<sup>-1</sup> in the synchronous 2D correlation spectra indicate that the formation reactions of carbamate and bicarbonate were strongly influenced by the changes in the pH related to the proton concentration. The conversion reaction of carbamate into bicarbonate via reaction 3 was confirmed by the negative cross peak at (1354, 1536) cm<sup>-1</sup> in the synchronous 2D correlation spectrum. An analysis of the asynchronous 2D correlation spectra elucidates that the reaction of CO<sub>2</sub> and NH<sub>3</sub> in aqueous solution proceeded with the reduction of pH as follows: the formation of carbamate via reaction 1, the formation of bicarbonate via reaction 2, the reduction of pH related to proton peak, and the conversion of carbamate into bicarbonate via reaction 3.

**Acknowledgment.** This research was supported by a Grant DC2-101-1-0-0 from Carbon Dioxide Reduction & Sequestration Research Center, one of the 21st Century Frontier Programs funded by the Ministry of Science and Technology of Korean government.

**Supporting Information Available:** This material is available free of charge via the Internet at <http://pubs.acs.org>.

### References and Notes

- (1) Bai, H.; Yeh, A. C. *Ind. Eng. Chem. Res.* **1997**, *36*, 2490–2493.

- (2) Li, X.; Hagaman, E.; Tsouris, C.; Lee, J. W. *Energy Fuels* **2003**, *17*, 69–74.
- (3) Yeh, A. C.; Bai, H. *Sci. Total Environ.* **1999**, *228*, 121–133.
- (4) Diao, Y. F.; Zheng, X. Y.; He, B. S.; Chen, C. H.; Xu, X. C. *Energy Convers. Manage.* **2004**, *45*, 2283–2296.
- (5) Meng, L.; Burris, S.; Bui, H.; Pan, W-P. *Anal. Chem.* **2005**, *77*, 5947–5952.
- (6) Hatch, T. F.; Pigford, R. L. *Ind. Eng. Chem. Fundam.* **1962**, *1*, 209–214.
- (7) Shale, C. C.; Simpson, D. G.; Lewis, P. S. *Chem. Eng. Prog. Symp. Ser.* **1971**, *67*, 52–58.
- (8) Yeh, J. T.; Resnik, K. P.; Rygle, K.; Pennline, H. W. *Fuel Process. Technol.* **2005**, *86*, 1533–1546.
- (9) Yeh, J. T.; Pennline, H. W.; Resnik, K. P.; Rygle, K. 3rd Annual Conference on Carbon Capture & Sequestration, Alexandria, VA, May 3–6, **2004**.
- (10) Dell'Amico, D. B.; Calderazzo, F.; Labella, L.; Marchetti, F.; Pampaloni, G. *Chem. Rev.* **2003**, *103*, 3857–3897.
- (11) Ozaki, Y.; Noda, I. *Two-Dimensional Correlation Spectroscopy: Applications in Vibrational Spectroscopy*, John Wiley & Sons, Inc.: New York, 2004.
- (12) Jung, Y. M.; Noda, I. *Appl. Spectrosc. Rev.* **2006**, *41*, 515–547.
- (13) Noda, I. *Appl. Spectrosc.* **1993**, *47*, 1329–1336.
- (14) Jung, Y. M.; Shin, H. S.; Czarnik-Matusewicz, B.; Noda, I.; Kim, S. B. *Appl. Spectrosc.* **2002**, *56*, 1568–1574.
- (15) Molburg, J. C.; Thimmapuram, P.; Doctor, R. D. Comparison of Salient Features of Alternatives CO<sub>2</sub> Recovery Process. A&WMA Annual Meeting, Cincinnati, June **1994**, 94-RA113.03.
- (16) Laporta, M.; Pegoraro, M.; Zanderighi, L. *Phys. Chem. Chem. Phys.* **1999**, *1*, 4619–4628.
- (17) Krevelen, V.; Hoftijzer, D. W.; Huntjens, F. J. *Rec. Trav. Chim. Pays-bas* **1949**, *68*, 191–216.
- (18) Fransco, D. L. *J. Chem. Phys.* **1964**, *41*, 2134–2140.
- (19) Moore, M. H.; Khanna, R. K. *Spectrochim. Acta A* **1991**, *47*, 255–262.
- (20) Khanna, R. K.; Moore, M. H. *Spectrochim. Acta A* **1999**, *55*, 961–967.
- (21) Park, J. Y.; Yoon, S. J.; Lee, H. *Environ. Sci. Technol.* **2003**, *37*, 1670–1675.

JP800991D